



**INNERLYNX<sup>®</sup>**  
**MODULAR MECHANICAL SEALS**

INNERLYNX<sup>®</sup> TYPE UL FIRE RATED 3 HOUR FIRE STOP 



ISO-9001:2015 CERTIFIED COMPANY - FM537405



**TECNOLOGÍA TOTAL**  
INGENIERÍA EN INTEGRIDAD Y CORROSIÓN  
[www.tecnologiatotal.net](http://www.tecnologiatotal.net)

[www.apsonline.com](http://www.apsonline.com)



## What Is Innerlynx® & Why Is It Used?

- Modular Mechanical Seal
- Made from synthetic rubber & industrial strength pressure plates
- offered in 21 different sizes for all pipe diameters ranging from 1/2" to 144"
- Forms hydrostatic seal up to 40 psig & up to 92.28 feet of head pressure
- Innerlynx® are used to seal the annular space between a inner/carrier pipe and the ID of a wall penetration
- Can be installed easily and quickly by on worker with no special tools
- Can be installed many times over the life of the installation
- Help absorb vibrations, shocks and sound waves and act a sound dampener and electrically isolate the inner/carrier pipe from the penetrated structure
- Manufactured and assembled in the U.S.A.

## Innerlynx® Applications

### Industrial & Mechanical

- Wall, Floor & Ceiling Penetrations
- Hospital Mechanical
- Quiet Rooms
- Electronic Equipment Rooms
- Fire Walls
- Boiler Rooms
- Aquariums
- HVAC Systems
- Plumbing - Commercial & Residential
- Swimming Pools
- Decorative Fountains
- Septic Tanks
- Parking Garage Column Protectors
- Vibrations, Shock & Sound Dampening
- Pumps & Tanks

*Ductile Iron*  
*Copper Tubing*  
*Steel Conduit*  
*SDR-35*  
*Glass Pipe*  
*Telecommunication Cable*

*PVC & CPVC*  
*Insulated Pipe*  
*Plastic Conduit*  
*Dual Containment*  
*Electrical Wire*  
*IPEX*

**CORE DRILLED & PRE-CAST OPENINGS**  
**HDPE & STEEL WALL SLEEVES**



Cut-away view of Infinity® wall sleeve & Innerlynx®

### Industrial & Mechanical cont.

- Power Plants
- Power Generation Dams
- Ship Bulkheads
- High-Pressure Tank Guards
- Water & Wastewater
- Cased Road Crossings
- Cased Railroad Crossings
- Bridge Pipeline Crossings
- Waste Water Treatment Plants
- Public Works
- Manholes & Precast Concrete Forms
- Oil & Gas
- Offshore Platforms
- Berms & Dikes around Tank Farms
- Electrical Isolation for Corrosion Protection

# Innerlynx® Models and Properties



**Model "C" Innerlynx® Modular Seal** is suitable for most standard applications including: above ground, direct underground burial, wet conditions and where cathodic protection is desired.  
 Type: Standard  
 Seal Element: EPDM (black)  
 Pressure Plates: Composite  
 Nuts & Bolts: Carbon Steel (Zinc plated)  
 Temp. range: -40 °F to +250 °F

**Model "S-316" Innerlynx® Modular Seal** is composed of a combination of stainless steel hardware, glass-filled epoxy resin and EPDM.  
 Type: Standard  
 Seal Element: EPDM (black)  
 Pressure Plates: Composite  
 Nuts & Bolts: Stainless Steel  
 Temp. range: -40 °F to +250 °F



**Model "L" Innerlynx® Modular Seal** is composed of a low durometer EPDM rubber suitable for conduit, insulated pipe, copper pipe or thin-walled pipe.  
 Type: Low Durometer  
 Seal Element: EPDM (blue)  
 Pressure Plates: Composite  
 Nuts & Bolts: Carbon Steel (Zinc plated)  
 Temp. range: -40 °F to +250 °F

**Model "L-316" Innerlynx® Modular Seal** is composed of stainless steel hardware, glass-filled epoxy resin and low durometer EPDM.  
 Type: Low Durometer  
 Seal Element: EPDM (blue)  
 Pressure Plates: Composite  
 Nuts & Bolts: Stainless Steel  
 Temp. range: -40 °F to +250 °F



**Model "O" Innerlynx® Modular Seal** is composed of Nitrile rubber which is suitable for most hydrocarbons, oils, hydraulic fluids, chemicals and solvents (gasoline, jet fuel, water, motor oil, kerosene, etc.).  
 Type: Oil resistant  
 Seal Element: Nitrile (green)  
 Pressure Plates: Composite  
 Nuts & Bolts: Carbon Steel (Zinc plated)  
 Temp. range: -40° to +210° F

**Model "OS-316" Innerlynx® Modular Seal** is composed of a combination of stainless steel hardware, glass-filled epoxy resin and nitrile.  
 Type: Oil/fuel resistant  
 Seal Element: Nitrile (green)  
 Pressure Plates: Composite  
 Nuts & Bolts: Stainless Steel  
 Temp. range: -40 °F to +210 °F



**Model "T" Innerlynx® Modular Seal** is composed of silicone able to endure extreme temperatures.  
 Type: Extreme Temperature  
 Seal Element: Silicone (grey)  
 Pressure Plates: Carbon Steel (Zinc plated)  
 Nuts & Bolts: Carbon Steel (Zinc plated)  
 Temp. range: -67 °F to +400 °F

**Model "T-S316PP" Innerlynx® Modular Seal** is composed of a combination of stainless steel hardware and silicone.  
 Type: Extreme Temperature  
 Seal Element: Silicone (grey)  
 Pressure Plates: Stainless Steel  
 Nuts & Bolts: Stainless Steel  
 Temp. range: -67 °F to +400 °F



**Model "UL" Innerlynx® Modular Seal** is composed of proprietary rubber where fire resistance is a must. Two seals must be in place for UL approval.  
 Type: UL approved (3 hr. fire rating)  
 Seal Element: Proprietary Silicone (red)  
 Pressure Plates: Carbon Steel (Zinc plated)  
 Nuts & Bolts: Carbon Steel (Zinc plated)  
 Temp. range: 3 hrs fire rating (1900 °F/3hrs)

**Model "UL-S316PP" Innerlynx® Modular Seal** is composed of a combination of stainless steel hardware and silicone. Two seals must be in place for UL approval.  
 Type: UL approved (3 hr. fire rating)  
 Seal Element: Proprietary Silicone (red)  
 Pressure Plates: Stainless Steel  
 Nuts & Bolts: Stainless Steel  
 Temp. range: 3 hrs fire rating (1900 °F/3hrs)

## Innerlynx® Modular Seal - Properties

Material Properties for Innerlynx® Modular Seal Elements

Property	ASTM Method	EPDM (Black)	EPDM (Blue)	Nitrile	Silicone	Silicone UL
Hardness	D-2240	50	40	50.50	50.50	50.50
Tensile	D-412	1828 psi	1828 psi	1200 psi	860 psi	860 psi
Elongation	D-412	784%	784%	600%	600%	600%
Compression Set	D-395	25% 22 hrs. @ 158 °F	25% 22 hrs. @ 158 °F	45% 22 hrs. @ 158 °F	38% 22 hrs. @ 350 °F	38% 22 hrs. @ 600 °F
Specific Gravity	D-297	1.15	1.15	1.42	1.30	1.30

Material Properties for Composite Pressure Plates

Property	ASTM Method	Value
Tensile Strength	D-638	27,000 psi
Stress at Break	D-638	28,000 psi
Elongation at Break	D-638	3%
Flexural Strength	D-790	40,000 psi
Flexural Modulus	D-790	1,300,000 psi
Izod Impact	D-256	2.0
Specific Gravity	D-792	1.39

Material Properties for Bolts and Nuts

Type	Tensile Strength
Carbon Steel	60,000 psi
Stainless Steel: 316 Stainless Steel	85,000 psi

# Innerlynx® Dimensions

Innerlynx® Assembly  
Front View

Innerlynx®  
Side View

Innerlynx® Assembly  
Side View/Cut Away

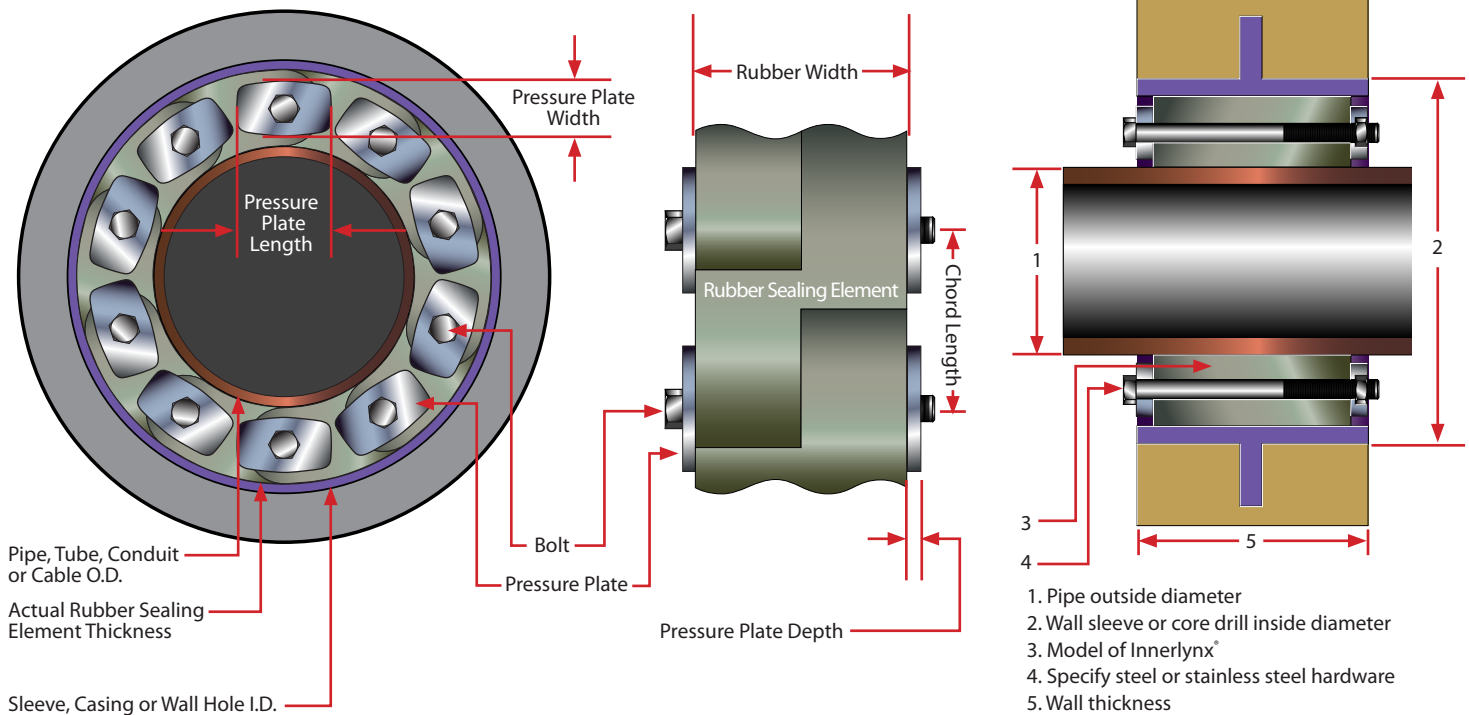

INNERLYNX® Model No.	RUBBER SEALING ELEMENT			PRESSURE PLATE			BOLT		Minimum Wall Thickness	Weight By Piece (lbs/approx)
	Actual Thickness	Width	Chord Length	Width	Length	Depth	Thread Size	Length (mm)		
IL200	0.50	1.80	1.15	0.45	1.14	0.32	5mm	65 (2.56")	2.500	0.05
IL265	0.59	1.77	1.58	0.55	1.49	0.37	5mm	70 (2.76")	2.875	0.10
IL275	0.63	1.80	0,89	0.63	0.90	0.36	5mm	65 (2.56")	2.500	0.05
IL300	0.70	2.57	1.50	0.68	1.52	0.43	8mm	100 (3.94")	3.625	0.20
IL310	0.65	2.40	2.22	0.63	2.00	0.50	6mm	90 (3.54")	3.750	0.22
IL315	0.83	2.49	1.47	0.79	1.46	0.48	8mm	90 (3.54")	3.625	0.25
IL325	0.93	3.04	3.15	0.81	2.87	0.94	8mm	130 (5.12")	5.125	0.60
IL340	1.02	2.75	1.52	0.96	1.50	0.70	8mm	115 (4.53")	5.125	0.35
IL360	1.25	2.80	2.08	1.12	2.10	0.76	8mm	115 (4.53")	5.125	0.50
IL400	1.41	3.56	3.63	1.33	3.51	1.06	10mm	155 (6.10")	6.250	1.20
IL410	1.41	3.38	2.62	1.42	2.52	0.87	10mm	140 (5.51")	5.625	0.80
IL425	1.13	3.54	3.60	1.03	3.45	1.18	10mm	155 (6.10")	6.250	0.69
IL440	1.74	3.36	3.94	1.52	3.54	0.96	10mm	150 (5.91")	6.125	1.00
IL475	1.61	3.16	2.68	1.48	2.60	0.78	10mm	140 (5.51")	5.625	0.90
IL500	2.39	3.90	3.90	2.17	3.72	1.04	12mm	155 (6.10")	6.250	2.30
IL525	2.20	3.80	3.95	2.00	3.72	1.03	12mm	155 (6.10")	6.250	2.15
IL575	1.81	3.78	3.16	1.79	3.01	1.00	12mm	155 (6.10")	6.250	1.55
IL600	3.20	4.08	6.06	3.07	6.12	1.90	12mm	205 (8.07")	8.250	6.25
IL625	3.28	4.02	4.09	3.08	3.93	1.18	12mm	180 (7.09")	8.250	3.25
IL650	2.67	4.07	4.16	2.17	3.72	0.87	12mm	155 (6.10")	6.250	2.50
IL700	3.74	3.98	6.02	3.58	5.85	1.12	12mm	180 (7.09")	8.250	5.25

\*All dimensions are in inches

# Innerlynx® Sizing & Ordering Information

## Innerlynx® Standard Sizing

For standard pipe penetrations, use the charts on pages 4, 5 and 6.

- Select the nominal pipe size, making sure the O.D. matches the application.
- Select one of the three recommended wall openings (APS Plastic Wall Sleeve, APS Steel Wall Sleeve, or Core Drilled Hole).
- Beginning at the column heading "Nominal Pipe Size", read across to the sizing selection for Core Drilled Hole or Sleeve Type. Inside the sizing selection column, the first column identifies the Core Drilled I.D. or Wall Sleeve Size. The second column provides number of Innerlynx® required to seal the penetration.

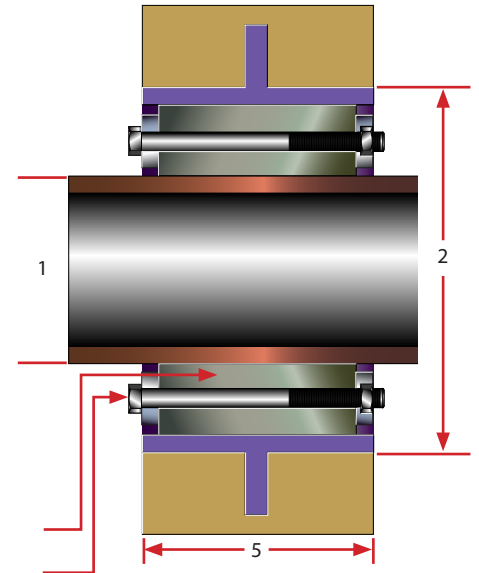

1. Pipe outside diameter
2. Wall sleeve or core drill inside diameter
3. Model of Innerlynx®
4. Specify steel or stainless steel hardware
5. Wall thickness

## INNERLYNX® Sizing Specifications - Standard Sizes

Nominal Pipe Size	Pipe OD (in.)	Recommended size for a Core Drilled Hole			Recommended size using APS Infinity® Wall Sleeve			Recommended size using APS Steel Wall Sleeve		
		Core Drill ID (in.)	Innerlynx® Size	IL's per Seal	Infinity® Wall Sleeve	Innerlynx® Size	IL's per Seal	Steel Wall Sleeve	Innerlynx® Size	IL's per Seal
<b>Cast Iron Soil Pipe (Extra Heavy)</b>										
2	2.375	4	IL300	6	IS-4	IL300	6	SWSW-4	IL300	6
3	3.500	5	IL300	8	IS-5	IL300	8	SWSW-5	IL300	8
4	4.500	6	IL300	10	IS-8	IL475	7	SWSW-6	IL300	10
5	5.500	8	IL340	14	IS-8	IL360	10	SWSW-8	IL340	14
6	6.500	10	IL400	7	IS-8	IL300	14	SWSW-10	IL475	9
8	8.625	12	IL400	9	IS-12	IL400	9	SWSW-12	IL400	9
10	10.750	14	IL400	10	IS-14	IL400	10	SWSW-14	IL425	10
12	12.750	16	IL400	12	IS-16	IL400	12	SWSW-16	IL425	12
15	15.875	18	IL325	17	IS-20	IL400	15	SWSW-20	IL400	15
<b>Cast Iron Soil Pipe (Service Weight)</b>										
2	2.250	4	IL315	6	IS-4	IL315	6	SWSW-4	IL315	6
3	3.250	5	IL315	8	IS-5	IL315	9	SWSW-5	IL315	8
4	4.250	6	IL315	10	IS-6	IL315	11	SWSW-6	IL315	11
5	5.250	8	IL360	10	IS-8	IL360	10	SWSW-8	IL360	10
6	6.250	8	IL315	15	IS-8	IL315	15	SWSW-8	IL315	15
8	8.375	10	IL300	18	IS-10	IL315	19	SWSW-10	IL300	19
10	10.500	14	IL475	14	IS-14	IL475	14	SWSW-14	IL360	17
12	12.500	16	IL475	16	IS-16	IL440	11	SWSW-16	IL425	12
15	15.625	20	IL575	18	IS-18	IL300	33	SWSW-20	IL475	20

# INNERLYNX® Sizing Specifications - Standard Sizes

Nominal Pipe Size	Pipe OD (in.)	Recommended size for a Core Drilled Hole			Recommended size using APS Infinity® Wall Sleeve			Recommended size using APS Steel Wall Sleeve		
		Core Drill ID (in.)	Innerlynx® Size	IL's per Seal	Infinity® Wall Sleeve	Innerlynx® Size	IL's per Seal	Steel Wall Sleeve	Innerlynx® Size	IL's per Seal
<b>Ductile Iron Pipe</b>										
2	2.500	4	IL300	6	IL-4	IL300	6	SWSW-4	IL300	6
2.25	2.750	4	IL265	6	IS-4	IL265	6	SWSW-4	IL275	10
3	3.960	6	IL315	10	IS-6	IL340	10	SWSW-6	IL340	10
4	4.800	8	IL410	7	IS-8	IL475	7	SWSW-8	IL410	7
6	6.900	10	IL400	7	IS-10	IL400	7	SWSW-10	IL400	7
8	9.050	12	IL400	9	IS-12	IL400	9	SWSW-12	IL400	9
10	11.100	14	IL400	10	IS-14	IL400	10	SWSW-14	IL340	24
12	13.200	16	IL425	13	IS-18	IL575	15	SWSW-16	IL325	14
14	15.300	18	IL425	14	IS-20	IL440	13	SWSW-20	IL575	17
16	17.400	20	IL425	16	IS-22	IL425	16	SWSW-22	IL575	19
18	19.500	22	IL425	18	IS-24	IL400	18	SWSW-24	IL575	21
20	21.600	26	IL575	24	IS-25	IL400	20	SWSW-24	IL300	46
24	25.800	30	IL575	28				SWSW-30	IL400	23
30	32.000	36	IL575	34				SWSW-36	IL400	29
36	38.300	43	IL525	32				SWSW-46	IL625	32
42	44.500	50	IL650	35				SWSW-50	IL525	37
48	50.800	56	IL500	43				SWSW-57	IL500	43
<b>Copper Tubing Pipe</b>										
0.5	0.625	2	IL275	4	IS-2	IL275	4	SWSW-2	IL275	4
0.75	0.875	2	IL200	4	IS-2	IL200	4	SWSW-2	IL200	4
1	1.125	2.5	IL275	6	IS-3	IL315	4	SWSW-2.5	IL275	6
1.25	1.375	2.5	IL200	5	IS-3	IL275	7	SWSW-2.5	IL200	5
1.5	1.625	3	IL275	7	IS-3	IL275	7	SWSW-3	IL275	7
2	2.125	4	IL315	6	IS-4	IL315	6	SWSW-4	IL315	6
2.5	2.625	4	IL275	10	IS-4	IL275	10	SWSW-4	IL275	10
3	3.125	5	IL315	8	IS-5	IL315	9	SWSW-5	IL315	8
4	4.125	6	IL315	10	IS-6	IL315	11	SWSW-6	IL315	11
6	6.125	8	IL315	15	IS-8	IL325	7	SWSW-8	IL315	15
8	8.125	10	IL315	19	IS-12	IL575	10	SWSW-12	IL575	10
10	10.125	14	IL575	12	IS-12	IL325	11	SWSW-14	IL400	10
12	12.125	16	IL575	14	IS-16	IL575	14	SWSW-16	IL400	11
<b>EMT - Thin Wall Steel Conduit</b>										
0.75	0.920	2	IL200	4				SWSW-2	IL200	4
1	1.160	2.5	IL275	6	IS-3	IL315	4	SWSW-2.5	IL275	5
1.25	1.510	3	IL275	7	IS-3	IL275	7	SWSW-3	IL300	4
1.5	1.740	3.5	IL315	5	IS-3.5	IL300	5	SWSW-3.5	IL315	5
2	2.200	4	IL315	6	IS-4	IL315	6	SWSW-4	IL315	6
2.5	2.875	4	IL200	9	IS-4	IL200	9	SWSW-4	IL200	9
3	3.500	5	IL300	8	IS-5	IL300	8	SWSW-6	IL360	7
4	4.500	6	IL300	10	IS-8	IL475	7	SWSW-6	IL300	10

# INNERLYNX® Sizing Specifications - Standard Sizes

Nominal Pipe Size	Pipe OD (in.)	Recommended size for a Core Drilled Hole			Recommended size using APS Infinity® Wall Sleeve			Recommended size using APS Steel Wall Sleeve		
		Core Drill ID (in.)	Innerlynx® Size	IL's per Seal	Infinity® Wall Sleeve	Innerlynx® Size	IL's per Seal	Steel Wall Sleeve	Innerlynx® Size	IL's per Seal
<b>IPS - Iron Pipe Size, Plastic Pipe Size, API Pipe Size, Electrical Conduit Size, or any pipe with same O.D.</b>										
0.5	0.840	2	IL200	4	IS-2	IL200	4	SWSW-2	IL200	4
0.75	1.050	2.5	IL275	6	IS-3	IL315	4	SWSW-2.5	IL275	5
1	1.315	2.5	IL200	5	IS-3	IL300	4	SWSW-2.5	IL200	5
1.25	1.660	3	IL275	7	IS-3	IL200	6	SWSW-3	IL275	7
1.5	1.900	3.5	IL300	5	IS-3.5	IL275	8	SWSW-3.5	IL300	5
2	2.375	4	IL300	6	IS-4	IL300	6	SWSW-4	IL300	6
2.5	2.875	4	IL200	9	IS-4	IL200	9	SWSW-4	IL200	9
3	3.500	5	IL300	8	IS-5	IL300	8	SWSW-5	IL300	8
3.5	4.000	6	IL315	10	IS-6	IL340	10	SWSW-6	IL315	11
4	4.500	6	IL300	10	IS-6	IL300	10	SWSW-6	IL300	10
5	5.563	8	IL340	14	IS-8	IL360	10	SWSW-8	IL340	14
6	6.625	10	IL400	7	IS-10	IL400	7	SWSW-10	IL400	7
8	8.625	12	IL400	9	IS-12	IL400	9	SWSW-12	IL400	9
10	10.750	14	IL400	10	IS-14	IL400	10	SWSW-14	IL425	10
12	12.750	16	IL400	12	IS-16	IL400	12	SWSW-16	IL425	12
14	14.000	18	IL575	16	IS-16	IL325	15	SWSW-18	IL400	13
16	16.000	20	IL575	18	IS-20	IL410	20	SWSW-20	IL400	15
18	18.000	22	IL575	20	IS-22	IL340	38	SWSW-22	IL400	17
20	20.000	24	IL575	22	IS-25	IL525	17	SWSW-24	IL400	18
22	22.000	26	IL575	24	IS-25	IL425	20	SWSW-26	IL400	20
24	24.000	28	IL575	26				SWSW-28	IL400	22
26	26.000	30	IL575	28				SWSW-30	IL400	23
28	28.000	32	IL575	30				SWSW-32	IL400	25
30	30.000	34	IL575	32				SWSW-34	IL400	27
32	32.000	36	IL575	34				SWSW-36	IL400	29
34	34.000	38	IL575	36				SWSW-40	IL500	29
36	36.000	40	IL575	38				SWSW-42	IL500	31
42	42.000	46	IL575	44				SWSW-48	IL500	36
48	48.000	52	IL575	49				SWSW-54	IL500	41
<b>SDR-35</b>										
4	4.215	6	IL315	10	IS-6	IL315	11	SWSW-6	IL315	11
6	6.275	8	IL315	15	IS-8	IL315	15	SWSW-8	IL300	14
8	8.400	10	IL300	18	IS-10	IL315	19	SWSW-10	IL300	19
10	10.500	14	IL475	14	IS-14	IL475	14	SWSW-14	IL360	17
12	12.500	16	IL475	16	IS-18	IL525	12	SWSW-16	IL425	12
15	15.300	18	IL425	14	IS-20	IL440	13	SWSW-20	IL575	17
18	18.701	22	IL400	17	IS-24	IL575	20	SWSW-22	IL425	17
21	22.047	26	IL575	24				SWSW-26	IL400	20
24	24.800	28	IL400	22				SWSW-28	IL425	22
27	27.950	32	IL575	30				SWSW-32	IL400	25
30	32.000	36	IL575	34				SWSW-36	IL400	29

# Innerlynx® Sizing

How to calculate sizes and amount of Innerlynx® needed to seal your penetration:

## Part 1

To figure which IL style number is needed to seal the annular space:

$$\text{I.D. of casing/core drilled hole} - \text{O.D. of carrier pipe} = Y$$

$$Y \div 2 = \text{Sealing Range}$$

Find the correct sealing range and the corresponding style number on the chart adjacent. If there is more than one IL size to choose from, choose the IL size that is closer to the untightened seal range.

## Part 2

To figure out how many Innerlynx® are needed to seal the penetration:

$$\text{I.D. of casing/core drilled hole} + \text{O.D. of carrier pipe} = Y$$

$$Y \div 2 = \text{Bolt Circle}$$

$$\text{Bolt Circle} \times 3.14 = \text{Circumference of bolt circle}$$

$$\text{Circumference of bolt circle} \div \text{chord length} = \text{Innerlynx® per seal}$$

Use the chord length matched with proper Innerlynx® number

### Example:

8" Ductile Iron Pipe into a 12" core drilled hole

#### Part 1:

$$12 - 9.05 = 2.95$$

$$2.95 \div 2 = 1.475 \text{ seal range}$$

1.475 falls between the range for IL 400

#### Part 2:

$$12 + 9.05 = 21.05$$

$$21.05 \div 2 = 10.525 \text{ Bolt Circle}$$

$$10.525 \times 3.14 = 33.0485 \text{ Circumference Bolt Circle}$$

Circle

$$33.0485 \div 3.63 = 9.10427 \text{ Number of Innerlynx®}$$

Answer: 9 IL400

Note: If the calculation ends in .79 or lower, round down to the nearest whole number. If the calculation ends in .80 or higher round up to the nearest whole number.

Also, please note that the number of Innerlynx® may vary from the online calculator due to the manual calculation not taking into account the deformation of the rubber when it conforms to the anchor space between the inner pipe and I.D. of the penetration.

Get your FREE Innerlynx® calculator app.

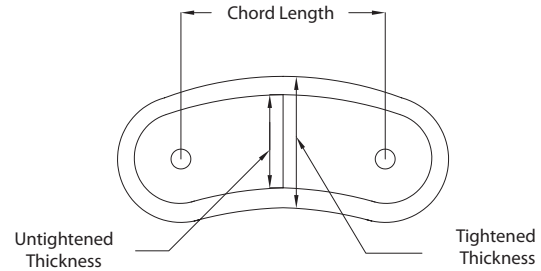

IL Size	Sealing Range		Chord Length	Min Qty	Min Pipe
	Untightened	Tightened			
200	0.50	0.63	1.15	4	0.84
265	0.59	0.79	1.58	5	1.90
275	0.63	0.78	0.89	4	0.50
300	0.70	0.88	1.50	4	1.32
310	0.65	0.88	2.22	6	3.96
315	0.83	1.03	1.47	5	1.63
325	0.93	1.19	3.15	7	6.63
340	1.02	1.32	1.52	5	1.38
360	1.25	1.65	2.08	5	2.13
400	1.41	1.81	3.63	6	6.13
410	1.41	1.81	2.62	5	2.75
425	1.13	1.50	3.60	7	6.90
440	1.74	2.19	3.94	8	8.13
475	1.61	2.00	2.68	5	2.38
500	2.39	2.81	3.90	8	8.13
525	2.20	2.50	3.95	8	8.13
575	1.81	2.35	3.16	8	6.13
600	3.20	4.00	6.06	8	12.13
625	3.28	4.00	4.09	9	8.13
650	2.67	3.20	4.16	10	10.75
700	3.74	4.32	6.02	8	12.13

## Having trouble sizing Innerlynx®?

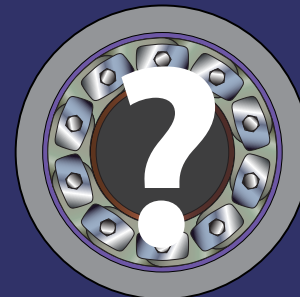

Call the factory with all information applicable: 1-800-315-6009  
 Online calculator available at [www.apsonline.com/innerlynx](http://www.apsonline.com/innerlynx)



# Wall Sleeves

## Why use Wall Sleeves?

Protect your investment using APS wall sleeves to provide a better seal than a core drilled hole. In the absence of wall sleeves, mechanical/utility piping vibration can cause costly damage. In addition, wall sleeves make it easier to repair piping without damaging the wall.

APS offers three types of wall sleeves designed to mate with Innerlynx® for leak free performance: Steel, Gal-vo-plast® coated steel and HDPE Infinity® Sleeves.

Each model is available with a 2" water stop that anchors the sleeve to prevent thrust movement and ensure positive water sealing. APS standard water stops are centered, unless otherwise requested.

## Infinity® Wall Sleeve Features

High Density Polyethylene (HDPE)

- Excellent resistance to acids, alkalis and other organic solvents
- Positive hydrostatic seal
- 16 sizes - 2" to 25" diameter
- Lighter than steel
- Resists water migration
- 16" long
- Locator caps make installation easier
- Adjust to wall thickness on-site



Model	I.D. (in.)	lbs
IS-2	1.950	1.06
IS-3	2.890	1.68
IS-3.5	3.360	1.85
IS-4	3.970	2.08
IS-5	5.110	2.82
IS-6	6.110	3.44
IS-8	8.125	5.00
IS-10	10.090	6.41
IS-12	12.070	9.06
IS-14	13.930	10.03
IS-16	16.050	12.01
IS-18	17.220	13.67
IS-20	18.920	14.24
IS-22	20.125	15.00
IS-24	22.563	17.70
IS-25	24.750	19.13

## Gal-vo-plast® Wall Sleeve Features

MODEL: GPWSW are made of steel with a welded steel water stop with Gal-vo-plast® coating.

- Less expensive than galvanized
- More corrosion resistant
- Faster availability, especially for custom wall sleeves
- Longer installation life
- All coating performed in house
- Considerably more economical
- Available in 2" to 120" diameter



Nominal Size (in.)	Sleeve I.D. (in.)
2	2.067
2.5	2.469
3	3.068
3.5	3.548
4	4.026
6	6.065
8	7.981
10	10.020
12	12.000
14	13.250
16	15.250
18	17.250
20	19.250
22	21.250
24	23.250
26	25.250
28	27.250
30	29.250
32	31.250
34	33.250
36	35.250
40	39.250
42	41.250

# Centering Blocks-End Seals

# Layered Applications

## Innerlynx® Centering Blocks

Around pipes of at least 14" in diameter, HDPE centering blocks are embedded into the bottom 25% of the Innerlynx® assembly to assist in centering the carrier pipe during installation.

Unlike pipeline "boots", when used as end seals, on pipes of these sizes, Innerlynx® are set within the casing and are protected from sharp aggregate and equipment, making them perfect end seals for cased pipelines.

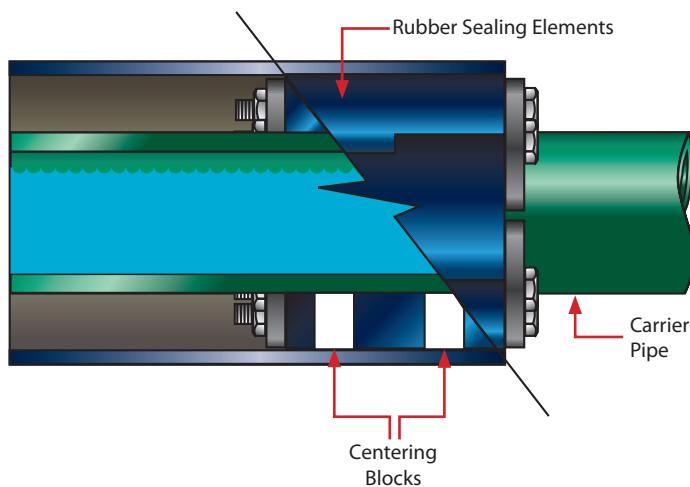

## Layered Applications

Multiple layers of Innerlynx® assemblies can be successfully installed using intermediate sleeves between wraps when the annular space is wider than the expanded thickness of a single Innerlynx® assembly (as seen in the example below). Call the factory for sizing assistance at 1-800-315-6009.

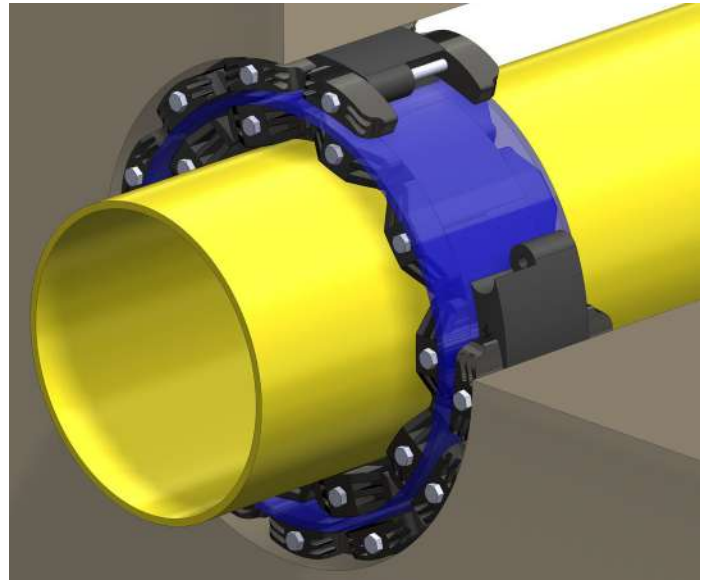

## Test Ports

### What is a Test Port?

A patent-pending pressure monitoring port that has been integrated into the Innerlynx® assembly. This design will not jeopardize the integrity of the sealing capacity, unlike other testing methods.

### Why are Test Port used?

They are used to test or monitor the operating pressure of an Innerlynx® application.

For more information on APS Test Ports, please visit our website at [www.apsonline.com/Innerlynx](http://www.apsonline.com/Innerlynx)



# Innerlynx® Installation Instructions



## Innerlynx® Check List

1. Make sure installation area is free of dirt or debris.
2. Make sure pipe is centered in sleeve or hole.
3. Make sure pressure plates and bolt heads are facing out.
4. Make sure that Innerlynx® are hand-tightened only.
5. Make sure that the carrier pipe is supported.
6. Make sure that you use an anti-seizing compound if using stainless steel hardware.



## Innerlynx® Don'ts

1. Never use power tools or air tools on any Innerlynx® bolt.
2. Do not tighten bolts more than a couple of turns at a time.
3. Do not tighten bolts completely at one time.
4. Do not use Innerlynx® as a mean of pipe support.
5. Do not install Innerlynx® on uneven surfaces.
6. Do not tighten in a star pattern. Do go clockwise.



## Please Read Above Before Installing



1. Center the pipe, cable or conduit in wall sleeve, casing or core drilled hole. Make sure the pipe will be adequately supported on both ends. Innerlynx® are not intended to support the weight of the pipe.



2. Connect both ends of the belt assembly around the pipe. Check to be sure all bolt heads are facing the installer.



3. Slide Innerlynx® assembly into annular space. Lubrication with thin soap/water solution may help if tight.



4. Assembly may fit tightly or be loose depending on fit designed for your annular space.



5. Use **HAND** tools only. **DO NOT USE** power or air driven tools. This not only voids your warranty, but does not let Innerlynx work to its full potential.



6. Start at the bolt located at 12 o'clock with 2-3 turns of wrench/ratchet. Continue clockwise. Do not tighten in a star pattern.



7. Repeat process until rubber begins to slightly bulge and bolt is tight. Make one more turn on each bolt around the entire assembly.



8. Installation is complete. If the seal doesn't appear to be correct using the instructions provided, call Advance Products & Systems, Inc. at 800-315-6009

## HOW TO ORDER

- Project Reference
- Carrier Pipe OD
- Wall Sleeve or Core Drilled ID
- Medium for application or Innerlynx Model
- Hardware (Steel or Stainless)
- Pressure Plates (Composite, Steel or Stainless)
- Wall Thickness (if applicable)

## OTHER PRODUCTS AVAILABLE

- Flange Isolation Gasket Kits
- Radolid® Nut & Bolt Protector Caps
- UBolt-Cote® & Atlas Pipe Support® Pads
- Casing Spacers and End Seals
- Kleerband® Flange Protectors
- Kleergel® Corrosion Inhibiting Grease
- Safety Spray Shields
- Foreman Nite Cap Pipe Plugs
- Bore Spacers
- ISOJOINT® Monolithic Isolating Joint



PO Box 60399 • Lafayette, Louisiana 70596-0399  
800-315-6009 • 337-233-6116 • FAX 337-232-3860  
E-Mail: sales@apsonline.com • Website: www.apsonline.com



Distributed by:



**TECNOLOGÍA TOTAL**  
INGENIERÍA EN INTEGRIDAD Y CORROSIÓN  
[www.tecnologiatotal.net](http://www.tecnologiatotal.net)

Advance Products & Systems, LLC is not responsible for errors printed in this brochure.

Advance Products & Systems, LLC shall repair or replace (within the limitations of such applicable express written warranty as may be issued by it) any product or portions thereof, which prove to be defective in workmanship or material for a period of 12 months from shipment date. The foregoing in lieu of all warranties, express or implied, and all other obligations or liabilities on the part of APS, on account of the product which it may sell. In no event shall APS be liable for consequential or special damages: nor except as it may otherwise specifically agree in writing, installation, or other work which may be done upon or in connection with the product by APS/the distributor/dealer or others. THE LIMITED WARRANTIES PROVIDED IN THIS AGREEMENT AND THE OBLIGATIONS AND LIABILITIES OF APS ARE THE ONLY WARRANTIES MADE BY APS AS TO THE PRODUCT. APS MAKES NO EXPRESS OR OTHER IMPLIED WARRANTIES, BY COURSE OF DEALING, USAGE OF TRADE, MERCHANTABILITY, FITNESS FOR A PARTICULAR USE (WHETHER GENERAL OR SPECIFIC), OR OTHERWISE.