

PRODUCT DESCRIPTION

TecnoSolda offers an exothermic welding solution that ensures permanent and high quality metal joints for connections in grounding systems and electrical circuits, which are often vulnerable to high currents and corrosion.

Characteristics and benefits of TecnoSolda:

- **Long-lasting molecular bonding:** Exothermic welding creates a molecular bond between metals, forming a strong and durable connection, ideal for extreme conditions.
- **Superior Electrical Performance:** Due to its high conductivity, TecnoSolda outperforms mechanical joints, optimizing current flow and minimizing electrical losses.
- **Corrosion Protection:** Its molecular composition significantly reduces the risk of corrosion, ensuring a long service life in grounding connections.
- **Application Versatility:** Widely used in sectors such as railways and electrical installations, TecnoSolda is the preferred choice for reliable grounding connections.

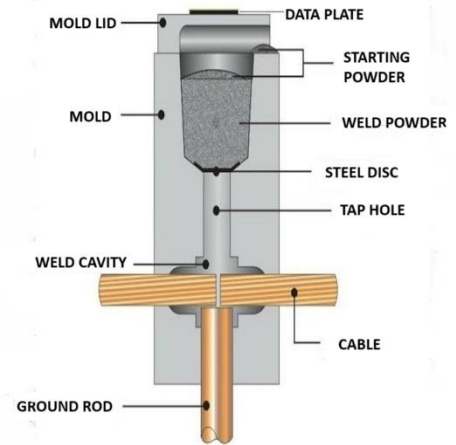

TecnoSolda Components: TECNOLOGÍA TOTAL supplies all the necessary elements for a complete exothermic weld, such as the welding mold, ignition gun and exothermic cartridge. This system offers a comprehensive solution for installations that demand permanent, highly conductive and reliable connections.

APPLICATION PROCESS

TecnoSolda exothermic welding allows reliable molecular joints between various metals, such as copper-copper, copper-steel (normal or galvanized), copper-copper-clad steel, copper-bronze, copper-bronze, copper-brass, copper-stainless steel and steel-steel, without the need for an external heat or energy source.

Process Description:

1. **Preparación de los Componentes:** El material de soldadura y el agente de ignición se colocan en un molde de grafito
Component Preparation: The solder material and ignition agent are placed in a graphite mold specific to each type of connection.
2. **High Temperature Reaction:** Once the ignition agent is ignited, an exothermic reaction occurs in which the aluminum reduces the copper oxide, generating molten copper and aluminum oxide at extremely high temperatures.
3. **Molecular Bonding:** The molten copper flows into the bond, forming a molecular bond between the metals and creating a solid and durable connection.

This process ensures a high-quality weld without requiring external heating equipment, providing a simple and efficient method for making permanent and resistant connections.

SECURITY PRECAUTIONS



Incorrect use of the product or improper preparation of conductors, molds or environment may result in aggressive reaction. Adequate protection is recommended in order to avoid contact with hot material. If work is performed in confined areas a respirator for metal dusts and fumes should be worn.

ENVIRONMENTAL PRECAUTIONS

Precautions must be taken to avoid hot material from coming into contact with fuel in the vicinity.

PRODUCTS PRESENTATION

The following table shows the presentation of the products required to perform the exothermic welding process.

PRODUCTO	DESCRIPCIÓN	PRESENTACIÓN	REFERENCIA
TecnoSolda TS15-25	The cartridge contains a mixture of copper oxide and aluminum oxide, which are stored in plastic containers. In addition to bringing a metal disc for each solder pack. This material reacts to produce heat with molten metals at temperatures above 1370°C and small amounts of fumes. This material is not sensitive to vibration or impact and is not subject to any form of spontaneous combustion.	Box of 20 units, 25g each cartridge. For cables #6 to #10.	
TecnoSolda Mold	The exothermic reaction takes place in a mold specially designed and fabricated in graphite. The molds are machined from a block of refractory material (graphite). Their lifetime under normal conditions of use is 50-100 welds. A metallic cover protects from projections at the moment of ignition.	Unit Cable #8	
TecnoSolda Flint gun	It is used for ignition of the ignition powder.	Unit	

TECHNICAL SUPPORT

For any technical questions regarding the use of our products, let us support you by contacting our technical sales department. Contact us, we have AMPP certified professionals in cathodic protection and industrial coatings ready to support you.

WARRANTY AND LIMITATION OF LIABILITY.

TECNOLOGÍA TOTAL shall in no event be liable for damages of any nature that may arise from improper use of the product. Before use, the user must determine whether or not the product is suitable for its intended use, assuming all risk and liability that may arise from its use.

If it is proven that a product is defective in material or workmanship at the time of sale, or does not meet during the warranty period the properties indicated in this datasheet, the sole responsibility of TOTAL TECHNOLOGY will be to replace the buyer the amount of product shown to be defective. TOTAL TECHNOLOGY assumes no responsibility for any additional costs such as manufacturing, removal or re-application costs of the products. If TOTAL TECHNOLOGY offers to its customer an express or implied warranty, or a compensation that differs from those set forth in this data sheet, such stipulation can only be altered by agreement signed by the parties.

